



### FEATURES

BMWC-L20R-4-BLE-KL is a 20A Receptacle with a built-in module that can be added to a BlueMesh network and be programmed to automatically switch loads on when occupancy is detected and off when the room becomes vacant.

### PHYSICAL DIMENSIONS

Unit:inch/mm

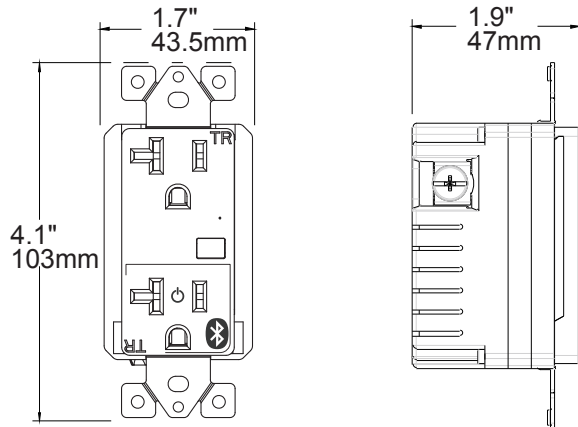

### TECHNICAL DATA

Input Voltage: AC120V  
 Frequency: 60Hz  
 Incandescent: 1500W  
 Standard Ballast: 1200VA  
 Electronic Ballast: 5A  
 Resistive: 2400W(20A)  
 Motor: 1 HP

Bluetooth Transmit: 100ft Max  
 Radio Frequency: 2.4GHz ± 75MHz  
 Bluetooth Version: 5.0  
 Housing Material: UL 94-5VA  
 Indoor Use Only  
 Operating Temperature: 0°C to 55°C,  
 32°F to 131°F  
 Storage Temperature: -30°C to 85°C,  
 -22°F to 185°F  
 IP Rating: IP20  
 Color: Plate/White,Housing/Black

Comply to UL244A, UL1376, RoHS  
 Safety: cULus Listed

### ORDERING INFORMATION

MODEL	DESCRIPTION
BMWC-L20R-4-BLE-KL	Bluetooth Plug Load Controller

## WIRING DIAGRAM

Ref#: 20240717

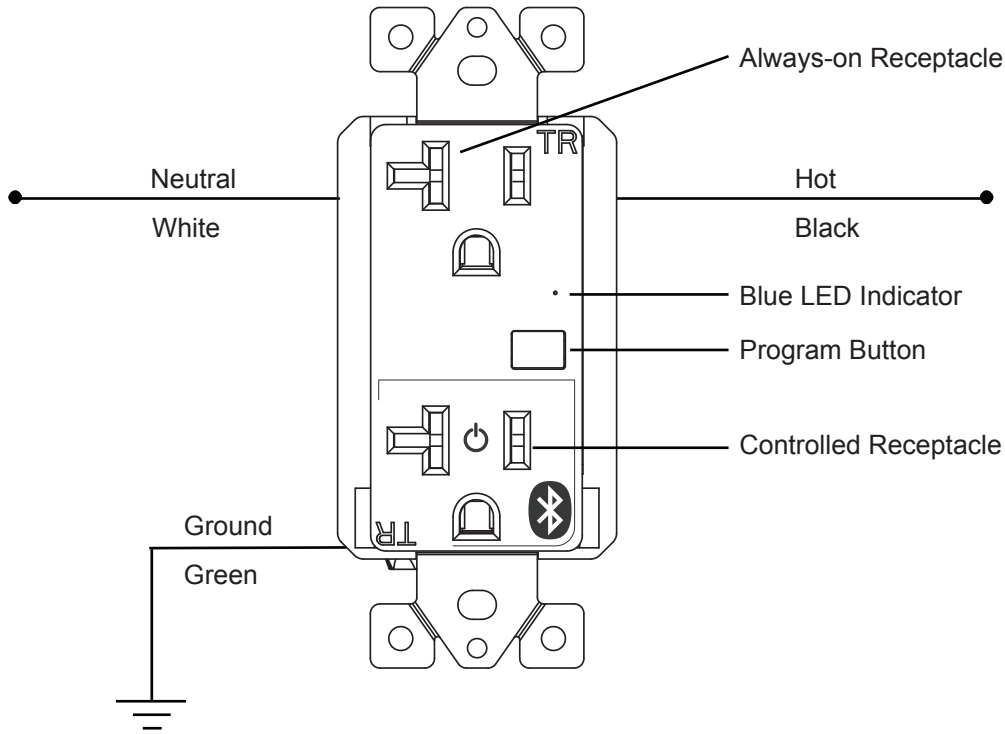

### LED Indicator:

Flashes on powering on or receiving wireless commands.

### Program Button:

Short press: Turn on/off Controlled receptacle.

Long press for 6 seconds: reset the controller to factory setting to be ready added by APP. You will hear gentle clicks of the relay when the controller being reset.

## WARRANTY

Five year limited warranty.

Specifications subject to change without notice.